

7130 Series - Floor & Overhead Closers

Floor springs 7130 series

Technical features

- Force EN 3 (20 Nm)
- Recommended for doors up to 100 kg
- Fixed French square spindle
- Hold open at 90°, 105° or non hold open
- Hydraulic control over 150° in both directions
- Two independent thermostatic valves for precise adjustment of general closing speed, final latch or final damping
- Large range of adjustment body setting in the cementing box : Width 7 mm
Length 11 mm
Height 5 mm
- Cast iron body and cementing box in hot zinc plated steel

All models have quality certification EN1154, version without hold open has CE conformity.

The floor springs are delivered complete with cementing box, body, fixed spindle and cover plate.

7130



PREFIT

FITTINGS FOR GLASS

7130 Series - Floor & Overhead Closers

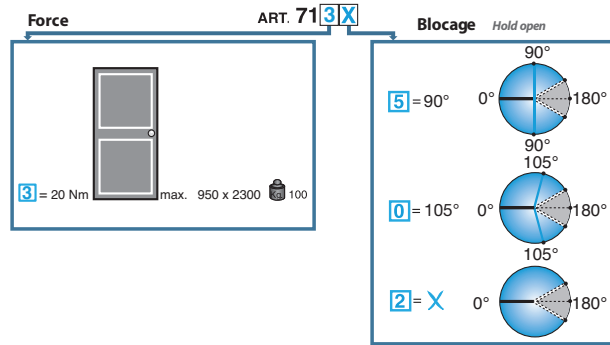
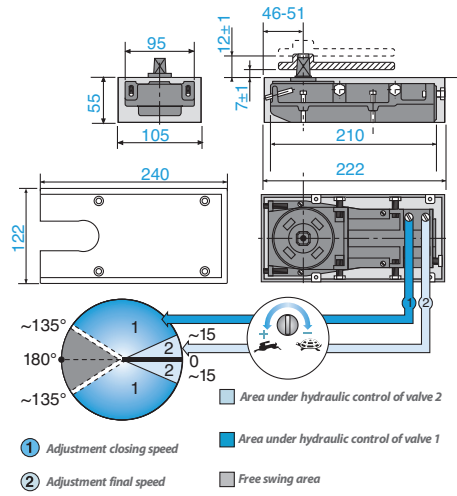

7130F

References



F

Floor spring force 3 EN, French square spindle, hold open at 105°



Polished brass Brushed stainless steel

7130F.00 **7130F.15**

7132F

References



F

Floor spring force 3 EN, French square spindle, no hold open



Polished brass Brushed stainless steel

7132F.00 **7132F.15**

7135F

References



F

Floor spring force 3 EN, French square spindle, hold open at 90°



Polished brass Brushed stainless steel

7135F.00 **7135F.15**



D

Floor spring force 3 EN, German rectangular spindle, hold open at 90°

7135D.00 **7135D.15**



I

Floor spring force 3 EN, Italian square spindle, hold open at 90°

7135I.00 **7135I.15**