

## Slidematic - Plug and Play Automatic Operators

### General technical features

- Sliding door operators for interior or exterior applications for single or double doors
- Swing door operators in push or pull version
- Low voltage operating with integrated power supply
- For 8, 10 and 12mm thick glass



### SLIDEMATIC1

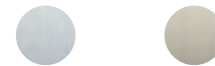
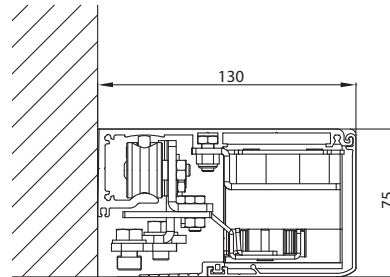

Brushed anodised alu. silver    Brushed anodised alu. aninox

#### References

Sliding door operator complete with cover and end caps for 'push and go' single door

**SLIDEMATIC1.12**    **SLIDEMATIC1.36**

- Operator length 2200 mm
- For maximum door width 1100 mm, max opening 1060 mm
- Maximum door weight 60 kg
- Provide fixing accessories for door SM01 or SM02 and floor guide SM600

### SLIDEMATIC2

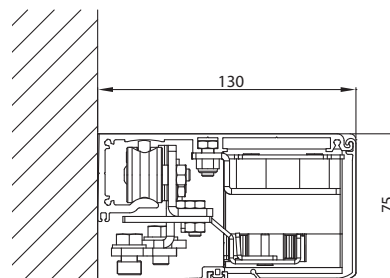

Brushed anodised alu. silver    Brushed anodised alu. aninox

#### References

Sliding door operator complete with cover and end caps for 'push and go' double doors

**SLIDEMATIC2.12**    **SLIDEMATIC2.36**

- Operator length 3300 mm
- For maximum 2 doors width 1100 mm, max opening 2160 mm
- Maximum door weight 80 kg for 2 doors
- Provide fixing accessories for door SM01 or SM02 and floor guide SM600

SLIDEMATIC ACCESSORIES

SM01.15

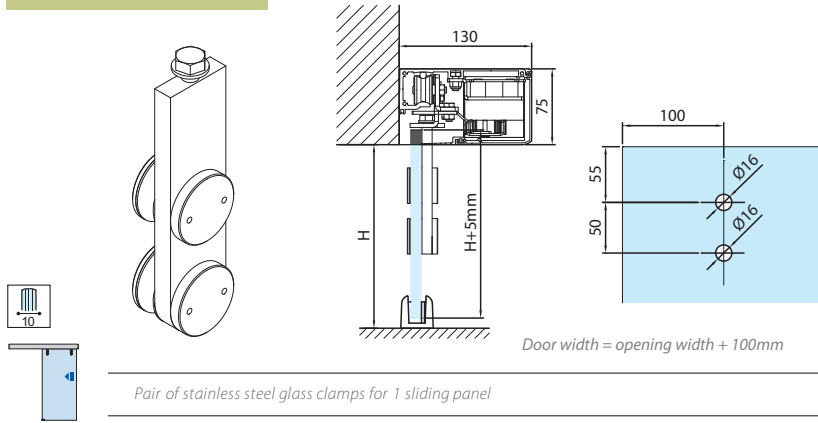

SM02.12

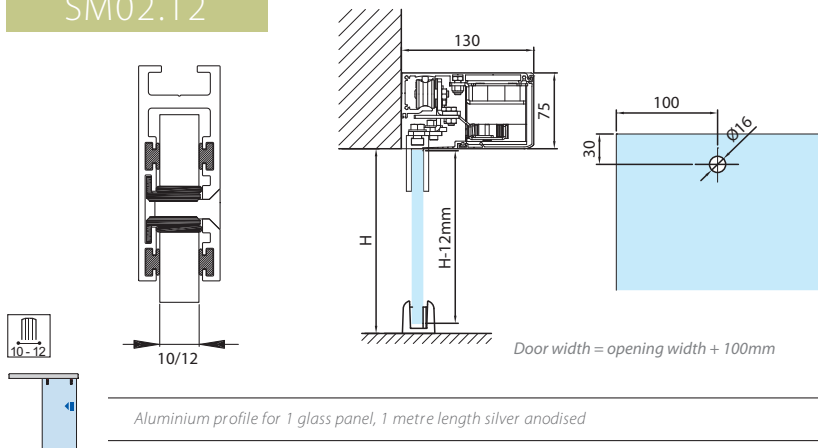

SM03.12

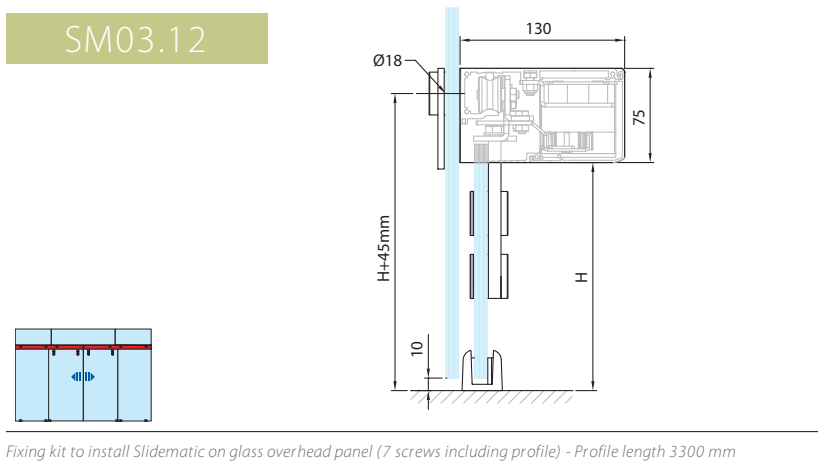

SM04.99



*Two way sensor*

SM05.99



*Movement and presence detection sensor*

SM06.99



*Dual technology sensor, microwave and active infrared, for safe operation*

SM600.99

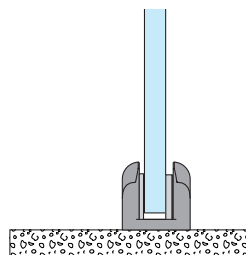
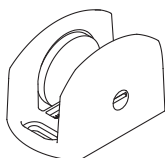

*Floorguide*