

# PREFIT

FITTINGS FOR GLASS



2007

## HINGES

SWINGO - SELF CLOSING HINGE

[www.prefit-fittings.com](http://www.prefit-fittings.com)

## Swingo – the all-new quality hinge from Prefit

### Self-closing hinge

Hinge for interior door of office or home that closes automatically the door after use. This type of hinge allows the door to be opened either by pushing or by pulling...

The use of Swingo hinges facilitates the installation of the door without modification to the door frame nor the surrounds. This solution equally offers an excellent aesthetic compromise for glass doors with accessories.

#### General characteristics

Blocking points at 90°

Tested 500,000 cycles

For glass thickness 8, 10, 12 mm

Acceptable maximum weight 60 kg

Width of the door 900 mm

Assembly on notch V861E

Delivered with spacers and screws

Unit of sale: 1 hinge



References	bright chromium	matt chromium	stainless steel effect	white
Wall to glass hinge	4861.30.0	4861.31.0	4861.35.0	4861.51.0
Glass to glass hinge	4862.30.0	4862.31.0	4862.35.0	4862.51.0

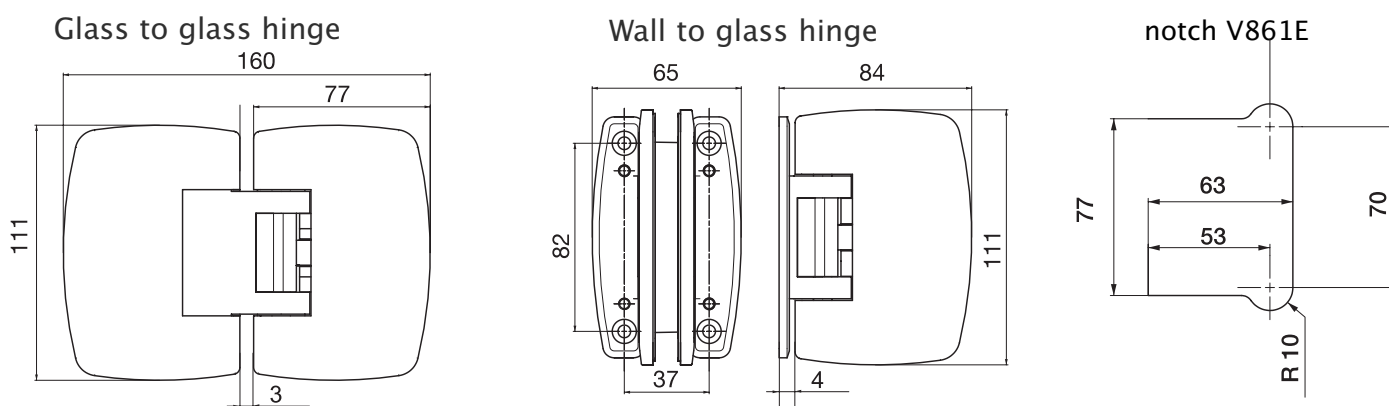

# P R E F I T

**FITTINGS FOR GLASS**

14 Sovereign Park, Coronation Road, London NW10 7QP

Tel: 020 8961 4777. Fax: 020 8961 4747

Email: sales@prefit-fittings.com

[www.prefit-fittings.com](http://www.prefit-fittings.com)



LRQ 0964 799

PREFIT IS A DIVISION OF  
J. PREEDY & SONS LIMITED